



APEX DYNAMICS, INC.

AF / AFR Series

Planetary Gearboxes

High Precision

High Speed

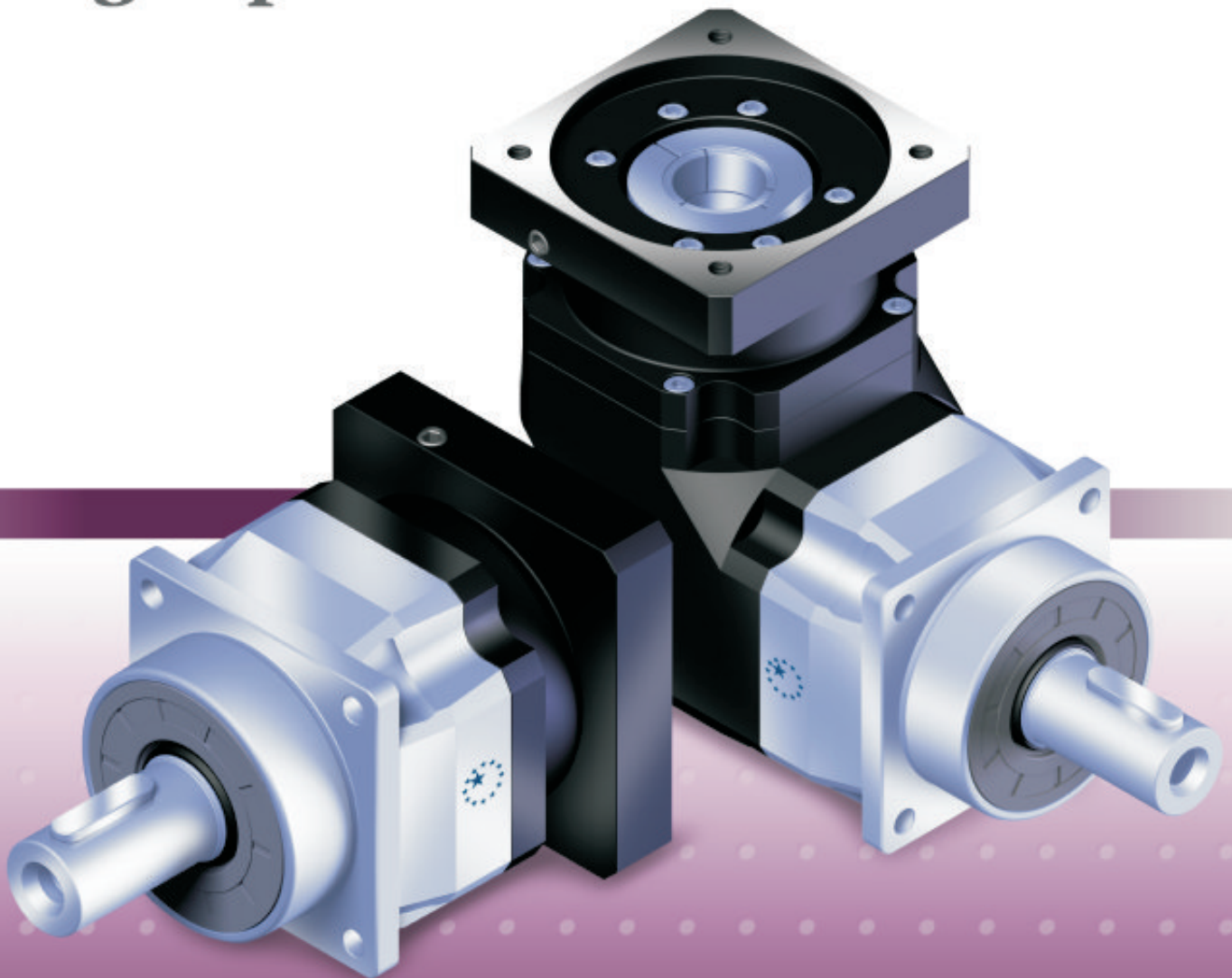

Stainless

AF / AFR Series

Characteristic Highlights



Equipped with **solid uncaged needle roller bearings**, provides maximum contact points to increase stiffness and generates high output torque.

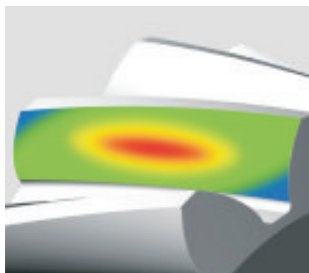

A high setting gear performance is achieved by using our **HeliTop technology**. This **eases off the tooth profile** and **crowns the lead of each tooth**. This optimizes the gear mesh alignment and overlap to achieve maximum tooth surface contact.

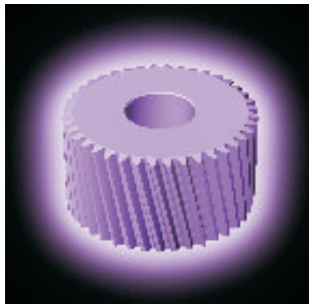

Our in house plasma nitriding heat treatment process maintains the tooth surface hardness at **900Hv** for superior wear-resistance and a core hardness at **30 HRC** for toughness.



One piece planet carrier with extended bearing design provides maximum radial load capacity and increases system reliability and stiffness.



True helical gear design
Precision helical gearing increases tooth to tooth contact ratio by over 33% vs spur gearing. The helix angle produces smooth and quiet operation with decreased backlash (less than 1 arc-minutes and $\leq 56\text{dB}$).

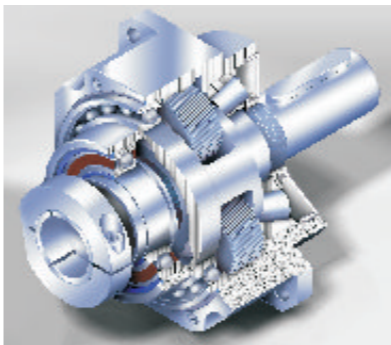

Patented planet carrier design puts the sun gear bearing directly into the planet carrier. It minimizes gear misalignment to gain higher accuracy.



Triple split collet with dynamic balanced set collar clamping system provides backlash free power transmission and eliminates slippage. 100% concentricity allows for smooth rotation and higher input speed capability.

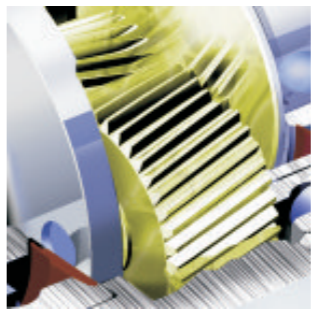

Lubricated with **Nyogel 792D** synthetic grease (Smart Grease) and sealed to **IP65** standards prevents leakage and is maintenance free.



Precision taper roller bearing support to increase radial and axial loading capacity.

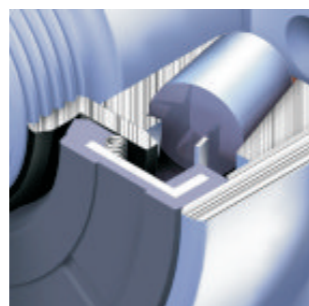
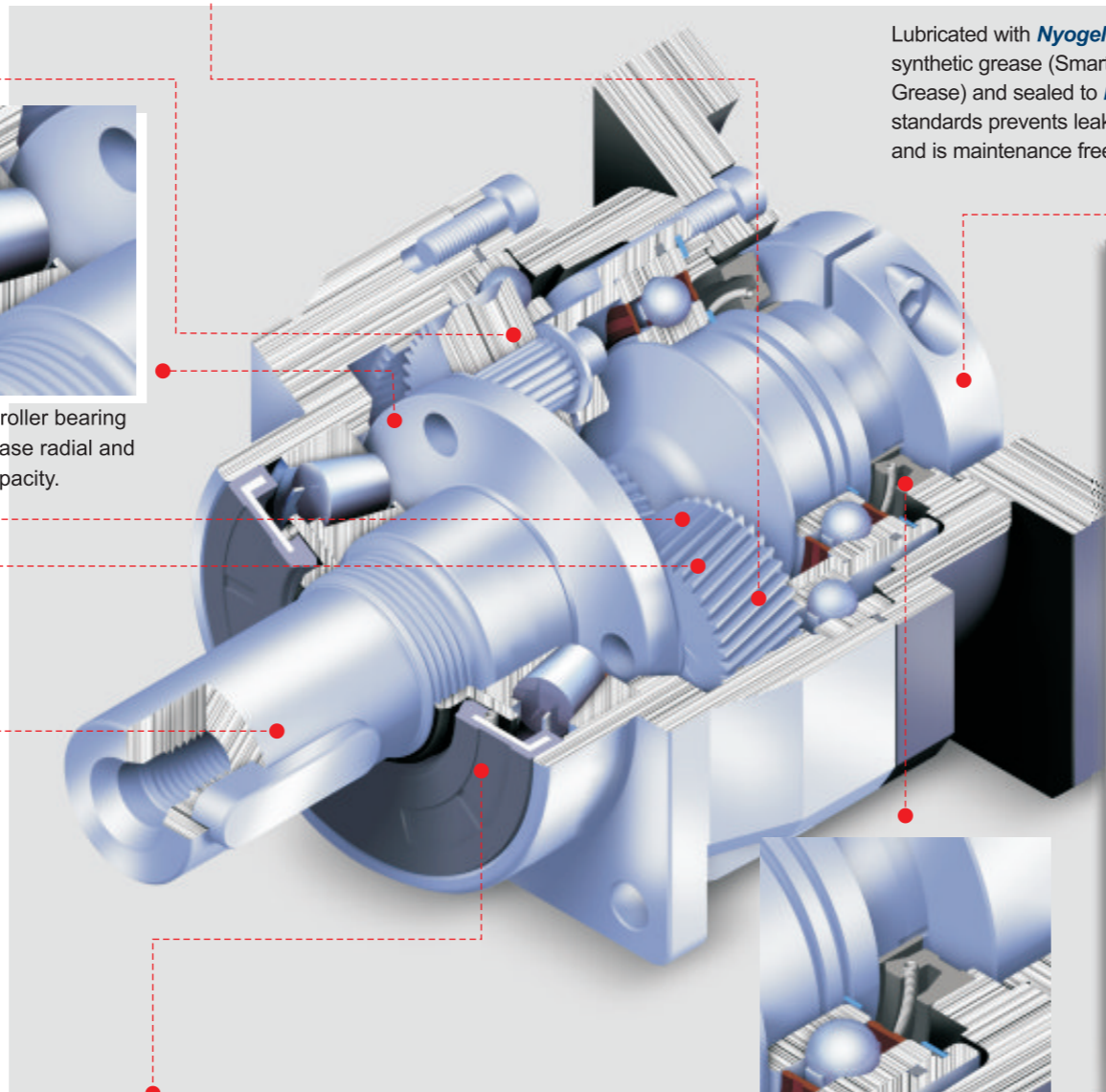

NEW - Patented output sealing systems design eliminates friction and heat generation which is accomplished by applying our hi-tech coating to all output contact surfaces. This coating reaches a hardness of **3700Hv** and is ground to $R_a 0.2 \mu\text{m}$ finish to ensure sealing.

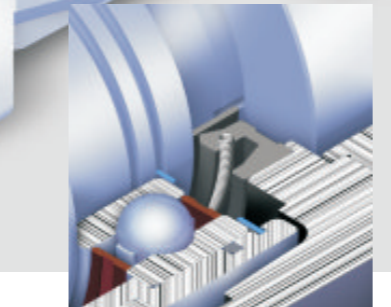

NEW - Patented input sealing system design eliminates break away torque and decreases friction/heat. The hi-tech coating bushing (**3700 Hv**, $R_a 0.2 \mu\text{m}$ finish) interfaces with our proprietary seal which decreases wear and erosion of both sealing surfaces. This new patent prevents leakage and has a service life of over 30,000 hours.

AFR Series

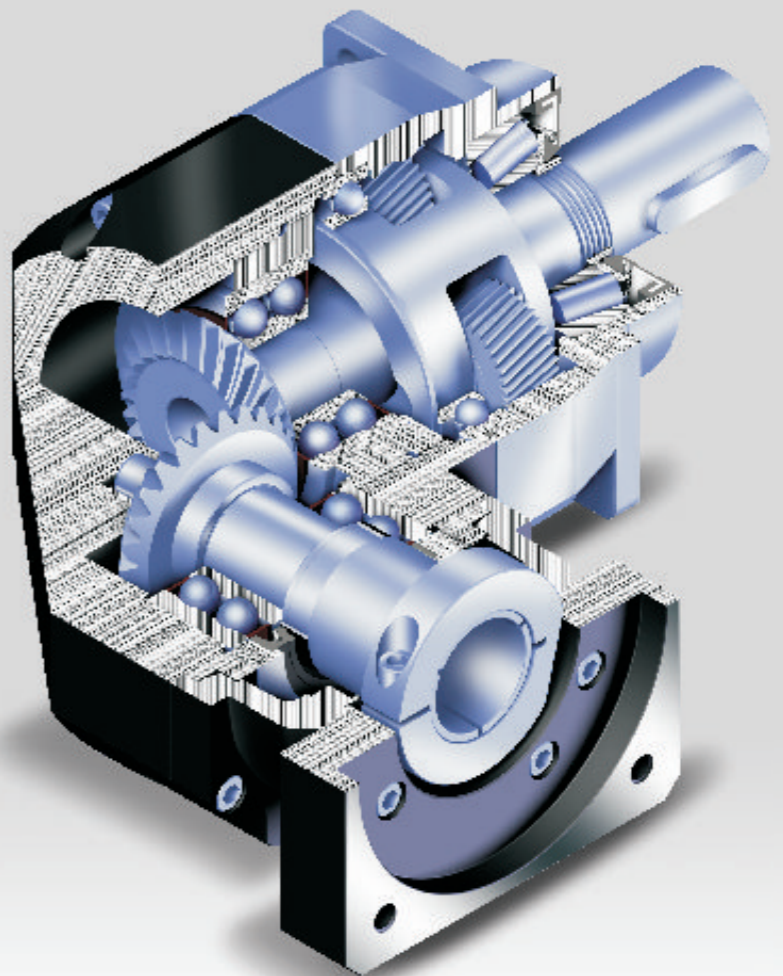

AFR version with 90° input via helical bevel gear. Featuring an extremely short, light yet rigid housing and full compatibility with standard motor adapters.

AF Series

Specifications

Gearbox Performance

Model No.	Stages	Ratio ¹	AF042	AF060	AF060A	AF075	AF075A	AF100	AF140	AF180	AF220	
Nominal Output Torque T_{2N}	1	3	20	55	-	130	-	208	342	588	1,140	
		4	19	50	-	140	-	290	542	1,050	1,700	
		5	22	60	-	160	-	330	650	1,200	2,000	
		6	20	55	-	150	-	310	600	1,100	1,900	
		7	19	50	-	140	-	300	550	1,100	1,800	
		8	17	45	-	120	-	260	500	1,000	1,600	
		9	14	40	-	100	-	230	450	900	1,500	
		10	14	40	-	100	-	230	450	900	1,500	
		2	15	20	55	55	130	130	208	342	588	1,140
			20	19	50	50	140	140	290	542	1,050	1,700
	25		22	60	60	160	160	330	650	1,200	2,000	
	30		20	55	55	150	150	310	600	1,100	1,900	
	35		19	50	50	140	140	300	550	1,100	1,800	
	40		17	45	45	120	120	260	500	1,000	1,600	
	45		14	40	40	100	100	230	450	900	1,500	
	50		22	60	60	160	160	330	650	1,200	2,000	
	60		20	55	55	150	150	310	600	1,100	1,900	
	70		19	50	50	140	140	300	550	1,100	1,800	
	80	17	45	45	120	120	260	500	1,000	1,600		
	90	14	40	40	100	100	230	450	900	1,500		
100	14	40	40	100	100	230	450	900	1,500			
Max. Output Torque T_{2B}	Nm	1,2	3 times of Nominal Output Torque									
Nominal Input Speed n_{1N}	rpm	1,2	3~100	5,000	5,000	5,000	4,000	4,000	4,000	3,000	3,000	2,000
Max. Input Speed n_{1B}	rpm	1,2	3~100	10,000	10,000	10,000	8,000	8,000	8,000	6,000	6,000	4,000
Micro Backlash P_0	arcmin	1	3~10	-	-	-	≤1	≤1	≤1	≤1	≤1	≤1
		2	15~100	-	-	-	-	-	≤3	≤3	≤3	≤3
Reduced Backlash P_1	arcmin	1	3~10	≤3	≤3	≤3	≤3	≤3	≤3	≤3	≤3	≤3
		2	15~100	≤5	≤5	≤5	≤5	≤5	≤5	≤5	≤5	≤5
Standard Backlash P_2	arcmin	1	3~10	≤5	≤5	≤5	≤5	≤5	≤5	≤5	≤5	≤5
		2	15~100	≤7	≤7	≤7	≤7	≤7	≤7	≤7	≤7	≤7
Torsional Rigidity	Nm/arcmin	1,2	3~100	3	7	7	14	14	25	50	145	225
Max. Radial Load F_{2rB} ²	N	1,2	3~100	610	1,400	1,400	4,100	4,100	9,200	14,000	18,000	33,000
Max. Axial Load F_{2a1B} ²	N	1,2	3~100	302	1,000	1,000	3,300	3,300	5,220	10,800	13,000	25,000
Max. Axial Load F_{2a2B} ²	N	1,2	3~100	320	1,100	1,100	3,700	3,700	5,820	11,400	19,500	16,300
Service Life	hr	1,2	3~100	30,000*								
Efficiency η	%	1	3~10	≥97%								
		2	15~100	≥94%								
Weight	kg	1	3~10	0.6	1.3	-	3.7	-	6.9	13.7	28	48
		2	15~100	0.8	1.5	2	4.1	5.5	8.1	16.6	33	60
Operating Temperature	°C	1,2	3~100	-10°C~+90°C								
Lubrication		1,2	3~100	synthetic gear grease (NYOGEL 792D)								
Degree of Gearbox Protection		1,2	3~100	IP65								
Mounting Position		1,2	3~100	all directions								
Noise Level ($n_1=3000$ rpm)	dB	1,2	3~100	≤56	≤58	≤60	≤60	≤63	≤63	≤65	≤67	≤70

Gearbox Inertia

Model No.	Stages	Ratio ¹	AF042	AF060	AF060A	AF075	AF075A	AF100	AF140	AF180	AF220	
Mass Moments of Inertia J	1	3	0.03	0.16	-	0.61	-	3.25	9.21	28.98	69.61	
		4	0.03	0.14	-	0.48	-	2.74	7.54	23.67	54.37	
		5	0.03	0.13	-	0.47	-	2.71	7.42	23.29	53.27	
		6	0.03	0.13	-	0.45	-	2.65	7.25	22.75	51.72	
		7	0.03	0.13	-	0.45	-	2.62	7.14	22.48	50.97	
		8	0.03	0.13	-	0.44	-	2.58	7.07	22.59	50.84	
		9	0.03	0.13	-	0.44	-	2.57	7.04	22.53	50.63	
		10	0.03	0.13	-	0.44	-	2.57	7.03	22.51	50.56	
		2	15	0.03	0.03	0.13	0.13	0.47	0.47	2.71	7.42	23.29
			20	0.03	0.03	0.13	0.13	0.47	0.47	2.71	7.42	23.29
	25		0.03	0.03	0.13	0.13	0.47	0.47	2.71	7.42	23.29	
	30		0.03	0.03	0.13	0.13	0.47	0.47	2.71	7.42	23.29	
	35		0.03	0.03	0.13	0.13	0.47	0.47	2.71	7.42	23.29	
	40		0.03	0.03	0.13	0.13	0.47	0.47	2.71	7.42	23.29	
	45		0.03	0.03	0.13	0.13	0.47	0.47	2.71	7.42	23.29	
	50		0.03	0.03	0.13	0.13	0.44	0.44	2.57	7.03	22.51	
	60		0.03	0.03	0.13	0.13	0.44	0.44	2.57	7.03	22.51	
	70		0.03	0.03	0.13	0.13	0.44	0.44	2.57	7.03	22.51	
	80	0.03	0.03	0.13	0.13	0.44	0.44	2.57	7.03	22.51		
	90	0.03	0.03	0.13	0.13	0.44	0.44	2.57	7.03	22.51		
100	0.03	0.03	0.13	0.13	0.44	0.44	2.57	7.03	22.51			

1. Ratio ($i=N_{in}/N_{out}$)

*S1 service life 15,000 hrs

2. Applied to the output shaft center @ 100 rpm

Dimensions (1-stage, Ratio $i=3\sim 10$)

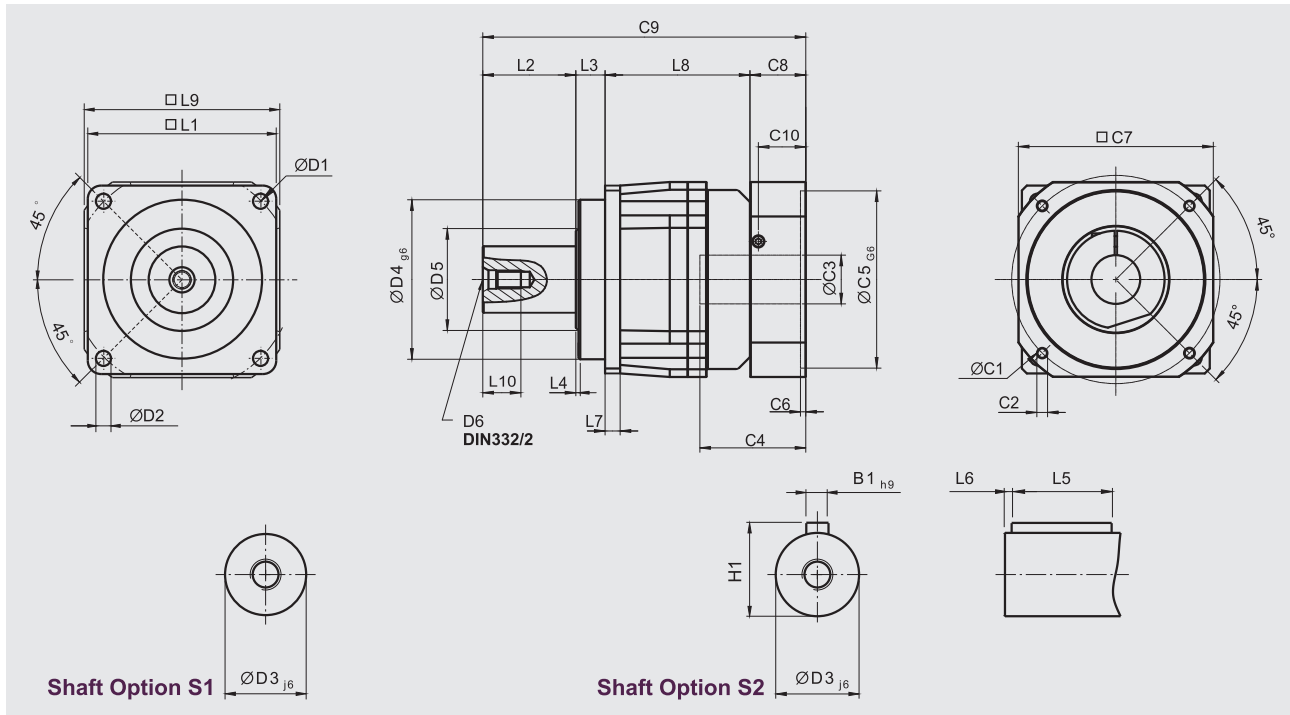

[unit: mm]

Dimension	AF042	AF060	AF075	AF100	AF140	AF180	AF220
D1	50	68	85	120	165	215	250
D2	3.4	5.5	6.8	9	11	13	17
D3 _{j6}	13	16	22	32	40	55	75
D4 _{g6}	35	60	70	90	130	160	180
D5	22	45	60	80	75	95	115
D6	M4 x 0.7P	M5 x 0.8P	M8 x 1.25P	M12 x 1.75P	M16 x 2P	M20 x 2.5P	M20 x 2.5P
L1	42	62	76	105	142	180	220
L2	19.5	28.5	36	58	82	82	105
L3	6.5	20	20	30	30	30	33
L4	1	1.5	2	2	3	3	3
L5	16	25	32	40	63	70	90
L6	2	2	3	5	5	6	7
L7	4	6	7	10	12	15	20
L8	31	54.5	86.5	89.5	110	150	163.5
L9	42	60	90	115	142	180	220
L10	10	12.5	19	28	36	42	42
C1 ³	46	70	100	130	165	215	235
C2 ³	M4 x 0.7P	M5 x 0.8P	M6 x 1P	M8 x 1.25P	M10 x 1.5P	M12 x 1.75P	M12 x 1.75P
C3 ³	≤11	* ≤14 / ≤16	≤19 / ≤24	≤32	≤38	≤48	≤55
C4 ³	25	34	40	50	60	85	116
C5 ³ _{G6}	30	50	80	110	130	180	200
C6 ³	3.5	8	4	5	6	6	6
C7 ³	42	60	90	115	142	190	220
C8 ³	29.5	19	17	19.5	22.5	29	63
C9 ³	86.5	122	159.5	197	244.5	291	364.5
C10 ³	8.75	13.5	10.75	13	15	20.75	53
B1 _{h9}	5	5	6	10	12	16	20
H1	15	18	24.5	35	43	59	79.5

3. C1~C10 are motor specific dimensions (metric std shown). Refer to Apexdyna.com and Design Tool to view your specific motor mounting system.
* AF060 ratio 5, 10 offers C3 ≤ 16 option.

AF Series

Dimensions (2-stage, Ratio $i=15\sim 100$)

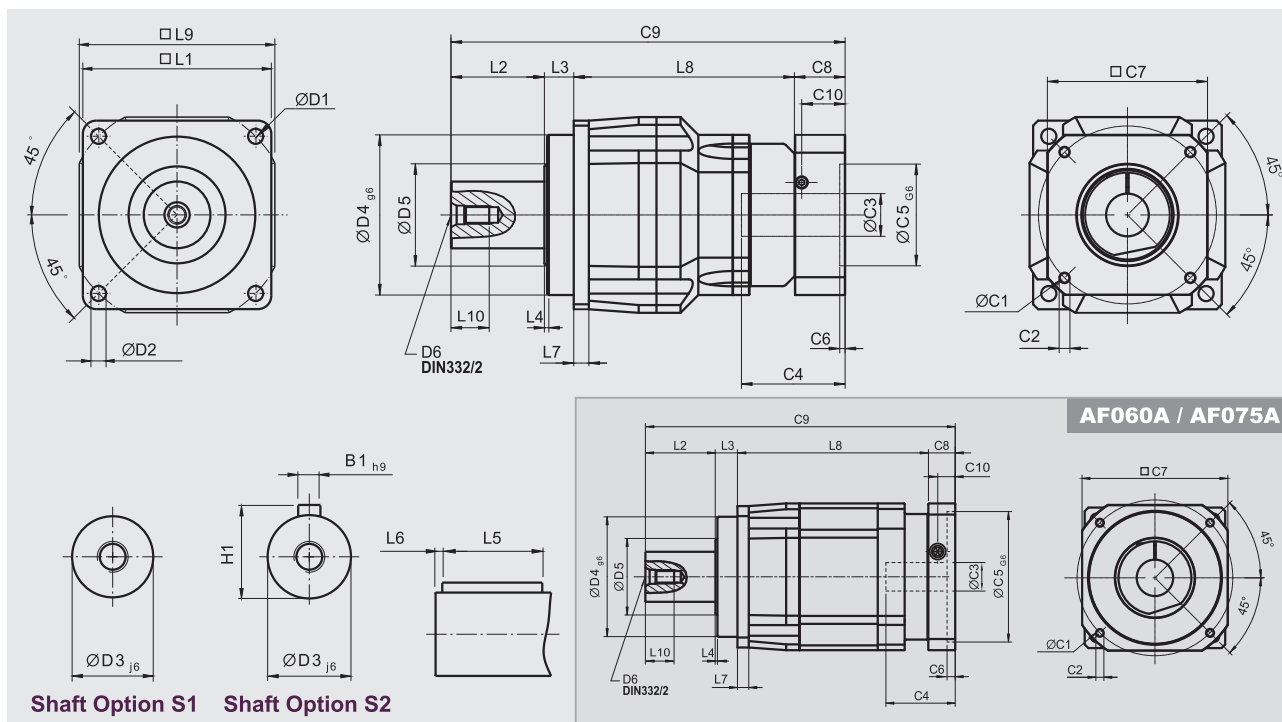

[unit: mm]

Dimension	AF042	AF060	AF060A	AF075	AF075A	AF100	AF140	AF180	AF220
D1	50	68		85		120	165	215	250
D2	3.4	5.5		6.8		9	11	13	17
D3 _{j6}	13	16		22		32	40	55	75
D4 _{g6}	35	60		70		90	130	160	180
D5	22	45		60		80	75	95	115
D6	M4 x 0.7P	M5 x 0.8P		M8 x 1.25P		M12 x 1.75P	M16 x 2P	M20 x 2.5P	M20 x 2.5P
L1	42	62		76		105	142	180	220
L2	19.5	28.5		36		58	82	82	105
L3	6.5	20		20		30	30	30	33
L4	1	1.5		2		2	3	3	3
L5	16	25		32		40	63	70	90
L6	2	2		3		5	5	6	7
L7	4	6		7		10	12	15	20
L8	58.5	65.5	91.5	119.5	134.5	131	166.5	205.5	248
L9	42	60		90		115	142	180	220
L10	10	12.5		19		28	36	42	42
C1 ³	46	46	70	70	100	100	130	165	215
C2 ³	M4 x 0.7P	M4 x 0.7P	M5 x 0.8P	M5 x 0.8P	M6 x 1P	M6 x 1P	M8 x 1.25P	M10 x 1.5P	M12 x 1.75P
C3 ³	≤11	*≤11 / ≤12	*≤14 / ≤16	≤14 / ≤15.875 / ≤16	≤19 / ≤24	≤19 / ≤24	≤32	≤38	≤48
C4 ³	25	25	34	34	40	40	50	60	85
C5 ^{3 G6}	30	30	50	50	80	80	110	130	180
C6 ³	3.5	3.5	8	8	4	4	5	6	6
C7 ³	42	42	60	60	90	90	115	142	190
C8 ³	29.5	29.5	19	19	17	17	19.5	22.5	29
C9 ³	114	143.5	159	194.5	207.5	236	298	340	415
C10 ³	8.75	8.75	13.5	13.5	10.75	10.75	13	15	20.75
B1 _{h9}	5	5	5	6	6	10	12	16	20
H1	15	18	18	24.5	24.5	35	43	59	79.5

4. C1-C10 are motor specific dimensions (metric std shown). Refer to Apexdyna.com and Design Tool to view your specific motor mounting system.

AFR Series

Specifications

Gearbox Performance

Model No.	Stages	Ratio ¹	AFR042	AFR060	AFR075	AFR100	AFR140	AFR180	AFR220	
Nominal Output Torque T_{2N}	1	3	9	36	90	195	342	588	1,140	
		4	12	48	120	260	520	1,040	1,680	
		5	15	60	150	325	650	1,200	2,000	
		6	18	55	150	310	600	1,100	1,900	
		7	19	50	140	300	550	1,100	1,800	
		8	17	45	120	260	500	1,000	1,600	
		9	14	40	100	230	450	900	1,500	
		10	14	40	100	230	450	900	1,500	
		14	-	42	140	300	550	1,100	1,800	
		20	-	40	100	230	450	900	1,500	
	2	15	14	-	-	-	-	-	-	-
		20	14	-	-	-	-	-	-	-
		25	15	60	150	325	650	1,200	2,000	
		30	20	55	150	310	600	1,100	1,900	
		35	19	50	140	300	550	1,100	1,800	
		40	17	45	120	260	500	1,100	1,600	
		45	14	40	100	230	450	900	1,500	
		50	14	60	100	230	650	1,200	2,000	
		60	20	55	150	310	600	1,100	1,900	
		70	19	50	140	300	550	1,100	1,800	
80	17	45	120	260	500	1,000	1,600			
90	14	40	100	230	450	900	1,500			
100	14	40	100	230	450	900	1,500			
120	-	-	150	310	600	1,100	1,900			
140	-	-	140	300	550	1,100	1,800			
160	-	-	120	260	550	1,000	1,600			
180	-	-	100	230	450	900	1,500			
200	-	-	100	230	450	900	1,500			
Max. Output Torque T_{2B}	Nm	1,2	3~200	3 times of Nominal Output Torque						
Nominal Input Speed n_{1N}	rpm	1,2	3~200	5,000	5,000	4,000	4,000	3,000	3,000	2,000
Max. Input Speed n_{1B}	rpm	1,2	3~200	10,000	10,000	8,000	8,000	6,000	6,000	4,000
Micro Backlash P_0	arcmin	1	3~20	-	-	≤2	≤2	≤2	≤2	≤2
		2	25~200	-	-	≤4	≤4	≤4	≤4	≤4
Reduced Backlash P_1	arcmin	1	3~20	≤4	≤4	≤4	≤4	≤4	≤4	≤4
		2	25~200	≤7	≤7	≤7	≤7	≤7	≤7	≤7
Standard Backlash P_2	arcmin	1	3~20	≤6	≤6	≤6	≤6	≤6	≤6	≤6
		2	25~200	≤9	≤9	≤9	≤9	≤9	≤9	≤9
Torsional Rigidity	Nm/arcmin	1,2	3~200	3	7	14	25	50	145	225
Max. Radial Load F_{2rB} ²	N	1,2	3~200	610	1,400	4,100	9,200	14,000	18,000	33,000
Max. Axial Load F_{2a1B} ²	N	1,2	3~200	302	1,000	3,300	5,220	10,800	13,000	25,000
Max. Axial Load F_{2a2B} ²	N	1,2	3~200	320	1,100	3,700	5,800	11,400	19,500	16,300
Service Life	hr	1,2	3~200	30,000*						
Efficiency η	%	1	3~20	≥95%						
		2	25~200	≥92%						
Weight	kg	1	3~20	0.9	2.1	6.4	13.9	23.7	50	83
		2	25~200	1.2	1.5	7.8	15.1	26.7	54	95
Operating Temp	°C	1,2	3~200	-10°C~+90°C						
Lubrication		1,2	3~200	synthetic gear grease (NYOGEL 792D)						
Degree of Gearbox Protection		1,2	3~200	IP65						
Mounting Position		1,2	3~200	all directions						
Noise Level ($n_1=3000$ rpm)	dB	1,2	3~200	≤61	≤63	≤65	≤68	≤70	≤72	≤74

Gearbox Inertia

Model No.	Stages	Ratio ¹	AFR042	AFR060	AFR075	AFR100	AFR140	AFR180	AFR220
Mass Moments of Inertia J_1	1	3~10	0.09	0.35	2.25	6.84	23.4	68.9	135.4
		14	-	0.07	1.87	6.25	21.8	65.6	119.8
		20	-	0.07	1.87	6.25	21.8	65.6	119.8
	2	15	0.09	-	-	-	-	-	-
		20	0.09	-	-	-	-	-	-
		25~100	0.09	0.09	0.35	2.25	6.84	23.4	68.9
120~200	-	-	0.31	1.87	6.25	21.8	65.6		

1. Ratio ($i=N_{in}/N_{out}$)

*S1 service life 15,000 hrs

2. Applied to the output shaft center @ 100 rpm

AFR Series

Dimensions (1-stage, Ratio $i=3\sim 20$)

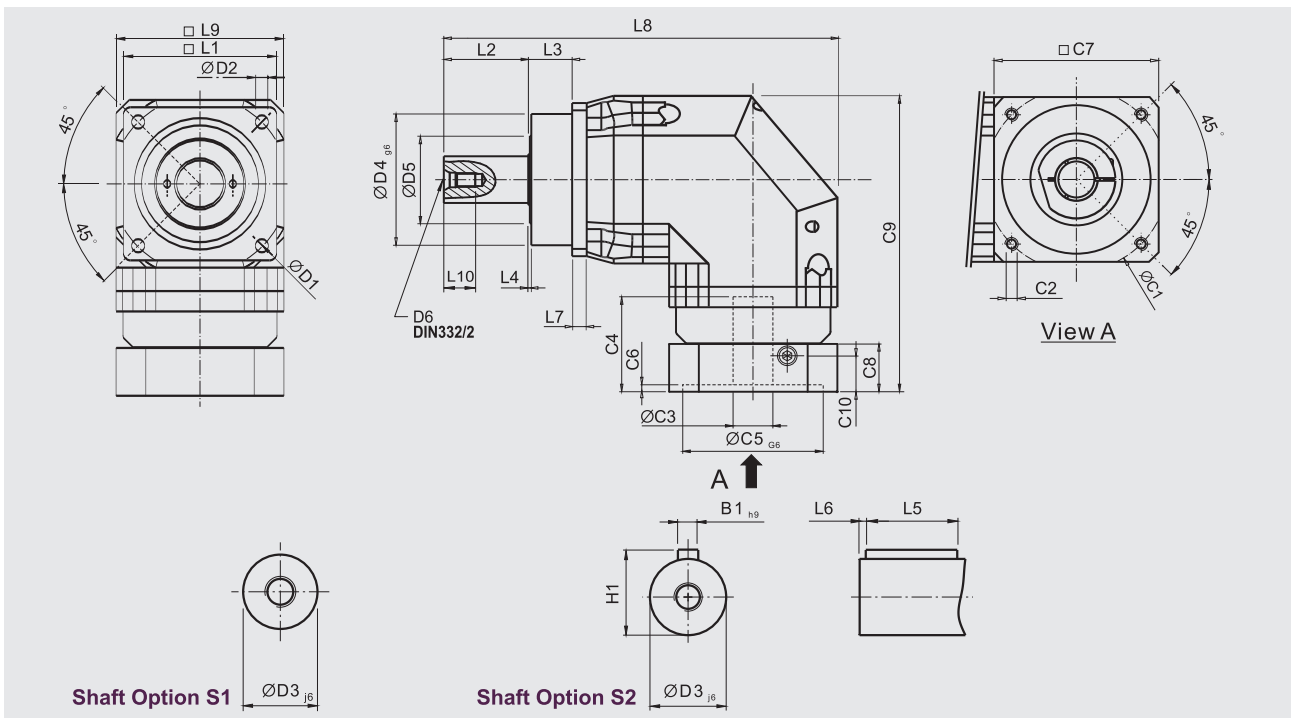

[unit: mm]

Dimension	AFR042	AFR060	AFR075	AFR100	AFR140	AFR180	AFR220
D1	50	68	85	120	165	215	250
D2	3.4	5.5	6.8	9	11	13	17
D3 _{j6}	13	16	22	32	40	55	75
D4 _{g6}	35	60	70	90	130	160	180
D5	22	45	60	80	75	95	115
D6	M4 x 0.7P	M5 x 0.8P	M8 x 1.25P	M12 x 1.75P	M16 x 2P	M20 x 2.5P	M20 x 2.5P
L1	42	62	76	105	142	180	220
L2	19.5	28.5	36	58	82	82	105
L3	6.5	20	20	30	30	30	33
L4	1	1.5	2	2	3	3	3
L5	16	25	32	40	63	70	90
L6	2	2	3	5	5	6	7
L7	4	6	7	10	12	15	20
L8	111.5	150	219	269.5	338.5	397	484
L9	42	60	90	115	142	180	220
L10	10	12.5	19	28	36	42	42
C1 ³	46	70	100	130	165	215	235
C2 ³	M4 x 0.7P	M5 x 0.8P	M6 x 1P	M8 x 1.25P	M10 x 1.5P	M12 x 1.75P	M12 x 1.75P
C3 ³	≤11	≤14 / ≤16	≤19 / ≤24	≤32	≤38	≤48	≤55
C4 ³	25	34	40	50	60	85	116
C5 ³ _{G6}	30	50	80	110	130	180	200
C6 ³	3.5	8	4	5	6	6	6
C7 ³	42	60	90	115	142	190	220
C8 ³	29.5	19	17	19.5	22.5	29	63
C9 ³	90.5	111.5	152.5	191.5	235.5	303.5	378.5
C10 ³	8.75	13.5	10.75	13	15	20.75	53
B1 _{h9}	5	5	6	10	12	16	20
H1	15	18	24.5	35	43	59	79.5

3. C1-C10 are motor specific dimensions (metric std shown). Refer to Apexdyna.com and Design Tool to view your specific motor mounting system.

Dimensions (2-stage, Ratio $i = 15 \sim 200$)

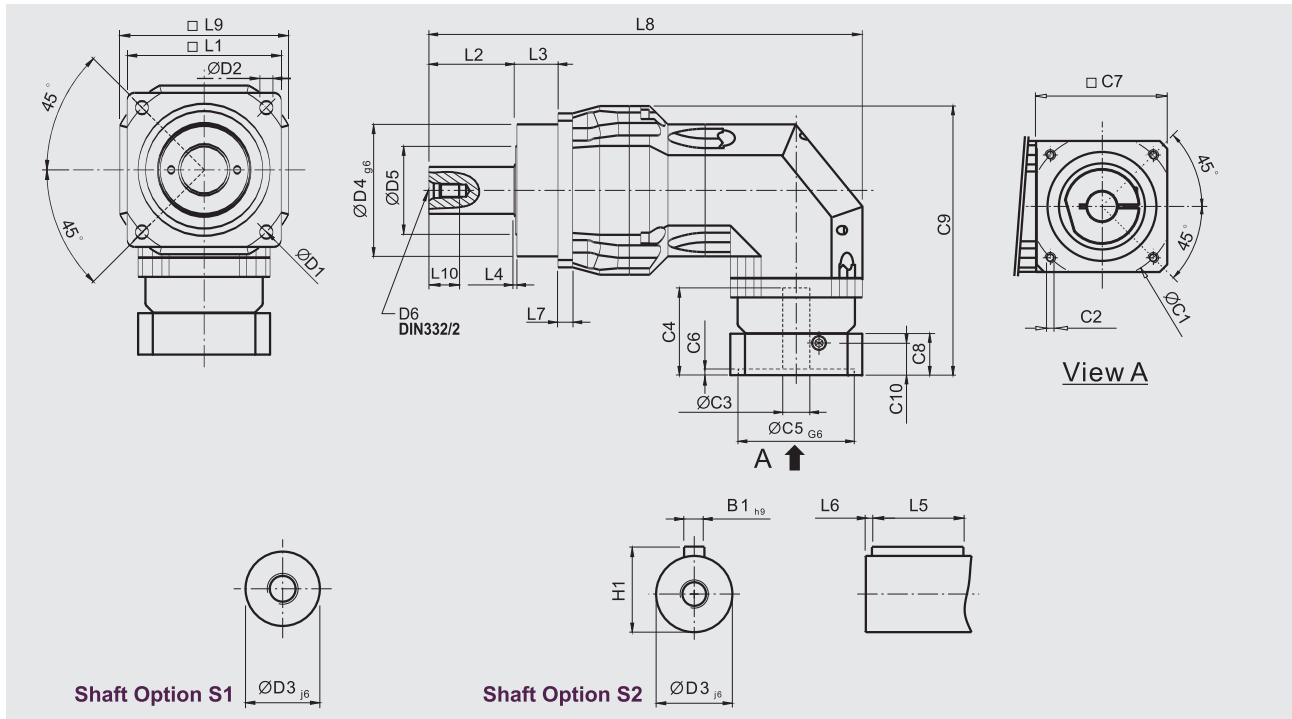

[unit: mm]

Dimension	AFR042	AFR060	AFR075	AFR100	AFR140	AFR180	AFR220
D1	50	68	85	120	165	215	250
D2	3.4	5.5	6.8	9	11	13	17
D3 _{j6}	13	16	22	32	40	55	75
D4 _{g6}	35	60	70	90	130	160	180
D5	22	45	60	80	75	95	115
D6	M4 x 0.7P	M5 x 0.8P	M8 x 1.25P	M12 x 1.75P	M16 x 2P	M20 x 2.5P	M20 x 2.5P
L1	42	62	76	105	142	180	220
L2	19.5	28.5	36	58	82	82	105
L3	6.5	20	20	30	30	30	33
L4	1	1.5	2	2	3	3	3
L5	16	25	32	40	63	70	90
L6	2	2	3	5	5	6	7
L7	4	6	7	10	12	15	20
L8	139	168.5	222.5	295.5	370.5	434	521
L9	42	60	90	115	142	180	220
L10	10	12.5	19	28	36	42	42
C1 ³	46	46	70	100	130	165	215
C2 ³	M4 x 0.7P	M4 x 0.7P	M5 x 0.8P	M6 x 1P	M8 x 1.25P	M10 x 1.5P	M12 x 1.75P
C3 ³	≤11	≤11 / ≤12	≤14 / ≤15.875 / ≤16	≤19 / ≤24	≤32	≤38	≤48
C4 ⁴	25	25	34	40	50	60	85
C5 ⁴ _{G6}	30	30	50	80	110	130	180
C6 ⁴	3.5	3.5	8	4	5	6	6
C7 ⁴	42	42	60	90	115	142	190
C8 ⁴	29.5	29.5	19	17	19.5	22.5	29
C9 ⁴	90.5	99.5	126.5	165	205	254.5	323.5
C10 ⁴	8.75	8.75	13.5	10.75	13	15	20.75
B1 _{h9}	5	5	6	10	12	16	20
H1	15	18	24.5	35	43	59	79.5

4. C1~C10 are motor specific dimensions (metric std shown). Refer to Apexdyna.com and Design Tool to view your specific motor mounting system.

Selection of the Optimum Gearbox

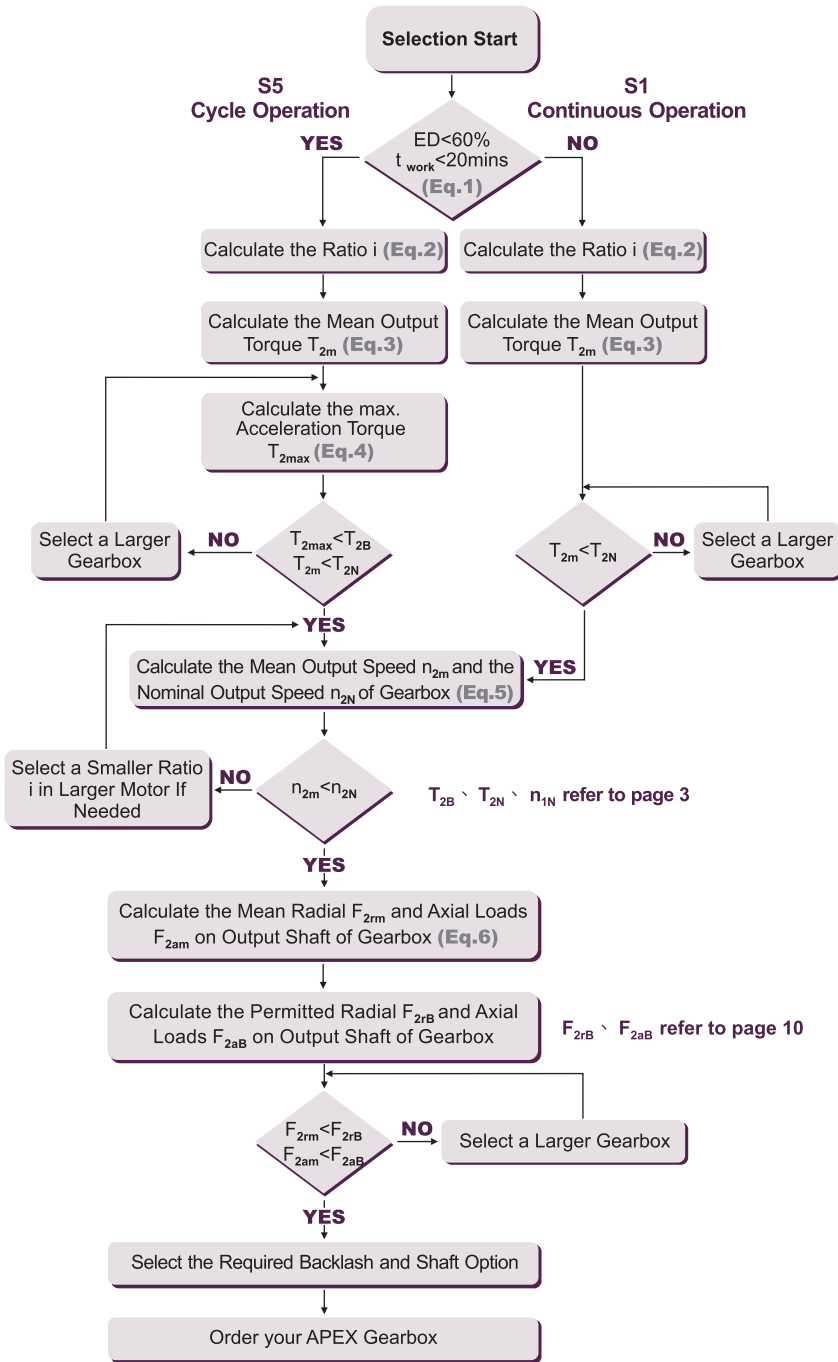

Recommended (for S5 Cycle Operation)

The general design is given for

$$\frac{J_L}{i^2} \leq 4 \times J_m$$

The optimal design is given for

$$\frac{J_L}{i^2} \cong J_m$$

J_L Load Inertia

J_m Motor Inertia

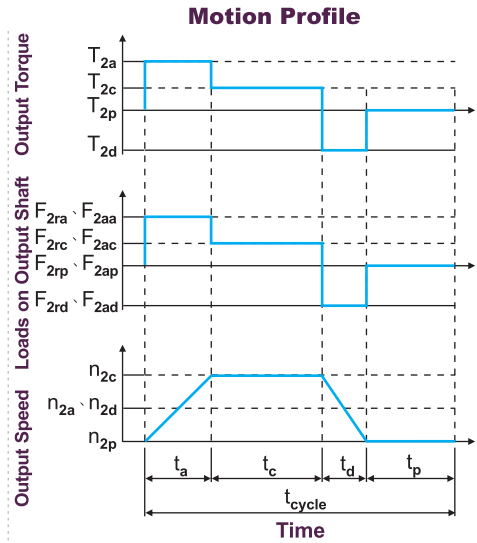

$$1. ED = \frac{t_a + t_c + t_d}{t_{cycle}} \times 100\%, t_{work} = t_a + t_c + t_d$$

Index : a. Acceleration, c. Constant, d. Deceleration, p. Pause (Eq.1)

$$2. i \cong \frac{n_m}{n_{work}}$$

n_m Output Speed of the Motor (Eq.2)
 n_{work} Working Speed

$$3. T_{2m} = 3 \sqrt{\frac{n_{2a} \times t_a \times T_{2a}^3 + n_{2c} \times t_c \times T_{2c}^3 + n_{2d} \times t_d \times T_{2d}^3}{n_{2a} \times t_a + n_{2c} \times t_c + n_{2d} \times t_d}}$$

(Eq.3)

$$4. T_{2max} = T_{mB} \times i \times k_s \times \eta$$

where K_s is

K_s	No. of Cycles / hr
1.0	0~1,000
1.1	1,000 ~ 1,500
1.3	1,500 ~ 2,000
1.6	2,000 ~ 3,000
1.8	3,000 ~ 5,000
2.0	5,000 ~ 9,000
2.05	9,000 ~ 10,000
not recommended	above 10,000

T_{mB} Max. Output Torque of the Motor (Eq.4)
 η Efficiency of the Gearbox

$$5. n_{2a} = n_{2d} = \frac{1}{2} \times n_{2c}$$

$$n_{2m} = \frac{n_{2a} \times t_a + n_{2c} \times t_c + n_{2d} \times t_d}{t_a + t_c + t_d}$$

$$n_{2N} = \frac{n_{1N}}{i}$$

(Eq.5)

$$6. F_{2rm} = 3 \sqrt{\frac{n_{2a} \times t_a \times F_{2ra}^3 + n_{2c} \times t_c \times F_{2rc}^3 + n_{2d} \times t_d \times F_{2rd}^3}{n_{2a} \times t_a + n_{2c} \times t_c + n_{2d} \times t_d}}$$

$$F_{2am} = 3 \sqrt{\frac{n_{2a} \times t_a \times F_{2aa}^3 + n_{2c} \times t_c \times F_{2ac}^3 + n_{2d} \times t_d \times F_{2ad}^3}{n_{2a} \times t_a + n_{2c} \times t_c + n_{2d} \times t_d}}$$

(Eq.6)

Permitted Radial and Axial Loads on Output Shaft of the Gearbox

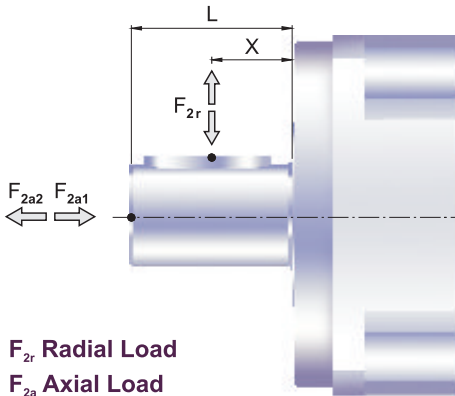

The permitted radial and axial loads on output shaft of the gearbox depend on the design of the gearbox supporting bearings. APEX use the extension straddle oversized ball bearing design. It can take heavy load from both axes.

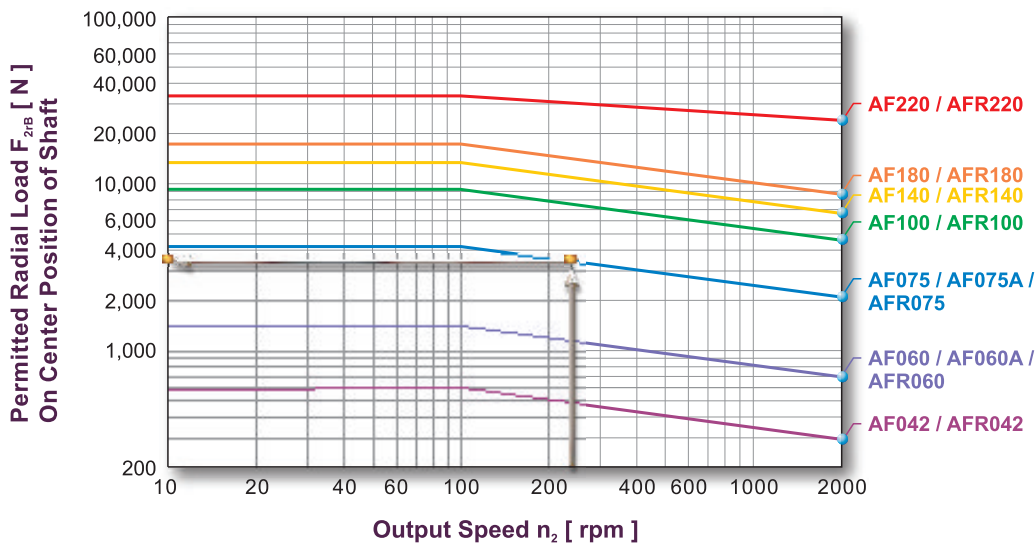

If radial force F_{2r} is exerted on the center of the output shaft $X=1/2 \times L$. Under various operating condition the lifetime is over 30,000 hours.* The permitted radial load is given on left diagram.

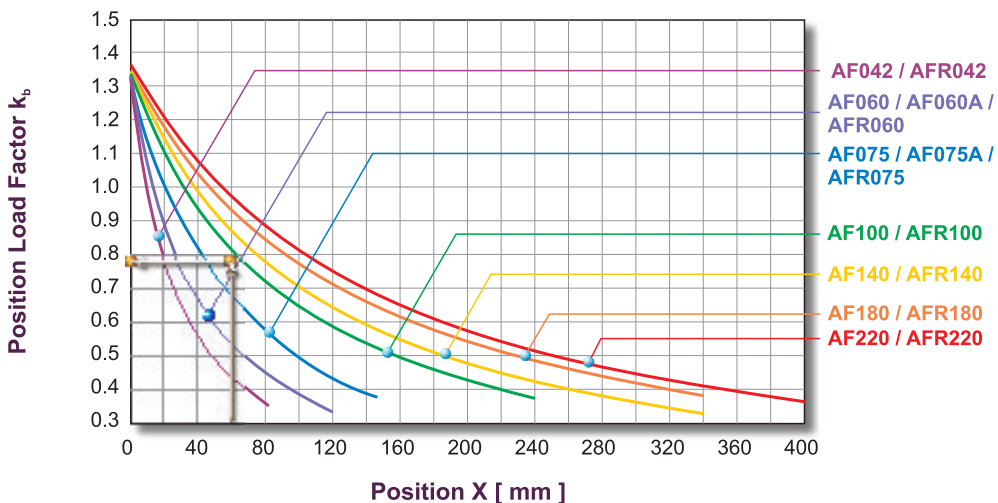

If radial force F_{2r} is not exerted on the center of the output shaft $X < 1/2 \times L$ or $X > 1/2 \times L$. The permitted radial and axial loads can be calculated by the position load factor k_b on the left diagram.

* S1 service life 15,000 hrs

Ordering Code

AF Series

AF075

-

010

-

S1

-

P1

/

MOTOR

Gearbox Size:

AF042, AF060, AF060A, AF075, AF075A
AF100, AF140, AF180, AF220

Shaft Option:

S1: Smooth Output Shaft
S2: Output Shaft with Key

Motor Designation:

Manufacturer Type
And Model

Ratio:

1 Stage: 3, 4, 5, 6, 7, 8, 9, 10
2 Stage: 15, 20, 25, 30, 35, 40, 45, 50, 60, 70,
80, 90, 100

Backlash:

P0: Micro Backlash
P1: Reduced Backlash
P2: Standard Backlash

Ordering Example: AF075-010-S1-P1 / SIEMENS 1FT6 041-4AF71

AFR Series

AFR075

-

010

-

S1

-

P1

/

MOTOR

Gearbox Size:

AFR042, AFR060, AFR075,
AFR100, AFR140, AFR180, AFR220

Shaft Option:

S1: Smooth Output Shaft
S2: Output Shaft with Key

Motor Designation:

Manufacturer Type
And Model

Ratio:

1 Stage: 3, 4, 5, 6, 7, 8, 9, 10, 14, 20
2 Stage: 15, 20, 25, 30, 35, 40, 45, 50, 60, 70,
80, 90, 100, 120, 140, 160, 180, 200

Backlash:

P0: Micro Backlash
P1: Reduced Backlash
P2: Standard Backlash

Ordering Example: AFR075-010-S1-P1 / SIEMENS 1FT6 041-4AF71

■ Please visit our website for newest update data.



APEX DYNAMICS, INC.

No. 6, 20th Rd., Taichung Industrial Park, Taichung, Taiwan, R.O.C.

Tel: 886 4 23550219 / Fax: 886 4 23550218

E-mail: sales@apexdyna.com

Website: www.apexdyna.com

